

FrymaKoruma Vacuum Deaerator

Continuous high performance deaeration

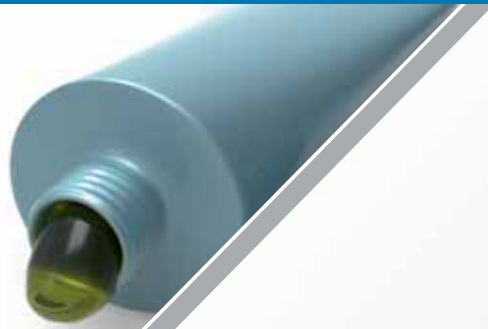

Continuous high performance deaeration

During continuous processing of liquid to high viscosity products, pockets of air or other gases can form in the product mass. This can create undesirable effects, such as oxidation – which may cause fats and oils to turn rancid, discoloration of products or changes in taste or odor. It can also cause fluctuations in specific weight. A dynamic process vacuum deaerator offers a highly efficient, cost-effective solution. This can be tailored to individual requirements, contributing both to quality assurance and process optimization.

Deaerated products have the following advantages:

- a smooth, glossy, foam-free surface
- chemically more stable and therefore a longer shelf life
- more dense, making precision dosage possible
- allowing lower pack volumes

To deaerate and remove air the product is fed onto a rotating disc in the vacuum vessel via a dosing valve. A distribution bell, which is axially movable, serves to vary the film thickness of the product and thus leads to an even distribution. Centrifugal force projects the product through a crown sieve against the inner wall of the vessel. This action breaks any pockets in the product mass, allowing the release of gases which are then extracted from the vessel by means of a vacuum pump. A discharge pump discharges the deaerated product to the next machine in the process.

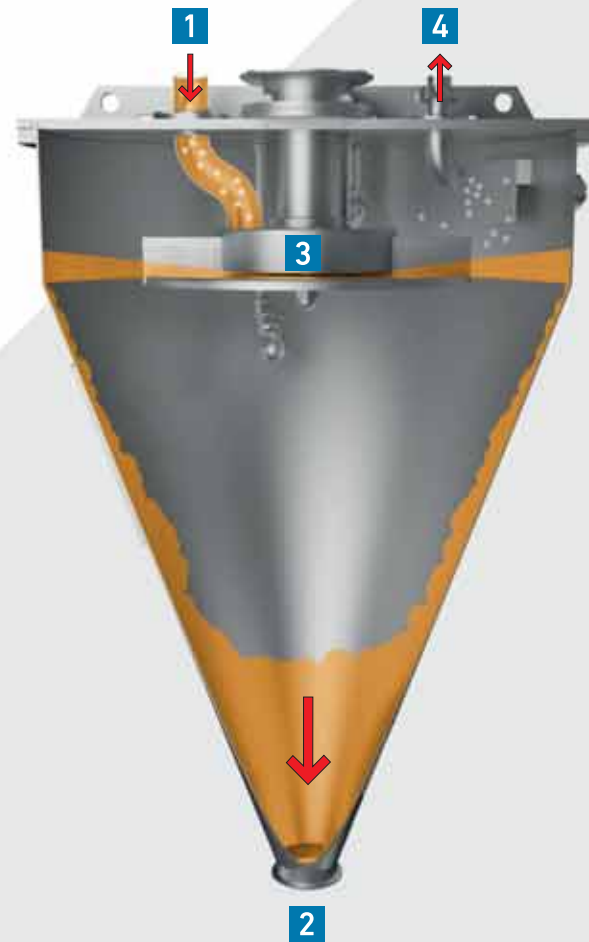

- 1 Product infeed
- 2 Product outlet
- 3 Distribution system
- 4 Vacuum system

Applications

Mustard

Dressing

Peanut butter

Cosmetics

Adhesive masses

Cream

Paper coating masses

Bread spreads

Ketchup

Shampoo

Sauces

Gels

Agro- and household chemicals



Options

The FrymaKoruma VE can be specially adapted to your needs by modular extensions:

- Riser pipe for high-foaming and high viscosity products
- Heating/cooling of vacuum vessel
- Pre-arrangement for CIP cleaning system
- Automatic level control
- Further options upon request



Key benefits

Efficient deaeration through

- large product surfaces
- rotating disc technology

Consistent product quality due to

- uniform product distribution
- less than 1% gas residue

Low monitoring effort due to

- automatic level control

Low operating costs due to

- low detergent consumption
- short cleaning time

High flexibility due to

- interchangeable sieve geometries
- various options

Minimum service effort due to

- quickly dismountable machine parts
- simple construction

User-friendly control through

- easy operation
- different levels of automation

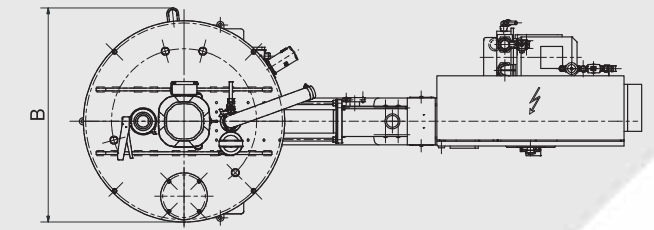
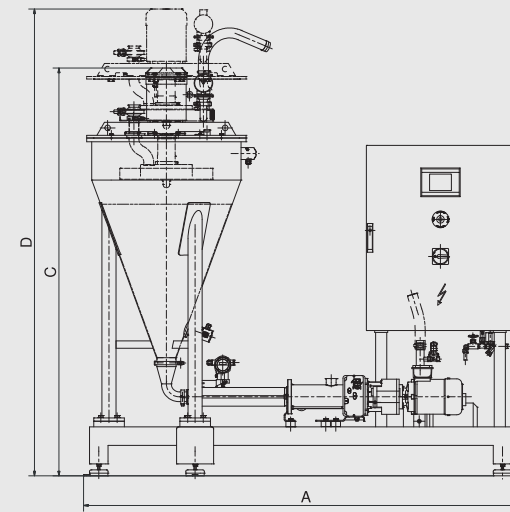

	Usable volume (l)	Throughput with liquid products (kg/h), approx.	Throughput with viscous products (kg/h), approx.	Throughput with highly viscous products (kg/h), approx.	Installed power (kW), approx.	Dimensions (mm)				Weight (kg), approx.
						Length A	Width B	Height C	Height* D	
VE I	25	1500	900	300	2,3	1650	560	1630	1740	475
VE II	65	4000	2500	800	4,5	1850	710	1770	2190	700
VE III	125	8000	5000	1600	6,6	2390	860	2200	2750	940
VE IV	300	15000	9000	3000	12,5	2460	1070	2680	3375	1400
VE V	550	20000	12500	4000	17	2840	1270	2860	3250	1600
VE VI	1200	30000	18000	6000	24	3460	1800	3670	4160	2200

*with open lid



Welcome to SWAT - The Customer Service you deserve!

Your targets:

- Make the best investment decision
- Reduce time to market
- Lower your break even point
- Fulfil your customer demands
- Increase your profitability
- Remain competitive

Our area of expertise:

- Consulting / Analysis / Research
- Speed / Quality / Compliance / Precision
- Efficiency / Safety / Hygiene / Automation
- Productivity / Sustainability
- Troubleshooting / Emergency / Used Machines
- Knowledge / Education

Let's aim for your targets, together!

FrymaKoruma AG
Theodorshofweg
4310 Rheinfelden / Switzerland
Tel. +41 61 8364-141
Fax +41 61 8312-000

ProXES Technology GmbH
Sales / ProTec
Fischerstraße 10
79395 Neuenburg / Germany
Tel. +49 7631 7067-0
Fax +49 7631 7067-29

info@frymakoruma.com
www.frymakoruma.com



member of >
ProXES
the processing > group