

ELEMENTRA[®] 29

Drum filling equipment

More efficiency, more safety. The drum filling ELEMENTRA[®] 29 has to offer driven conveyor systems and numerous accessories for handling empty and filled containers. The semi-automatic equipment adapts very well to particular requirements of the filling product or the respective environment due to a wide range of peripheral equipment. ATEX design available depending on the field of application.

BENEFITS

- Any number of drive units can be controlled
- Four stainless steel load cells
- Conveyor installed
- Short delivery time
- Easy maintenance
- Components in stainless steel and acid protection design available
- Variety of essential accessories



TECHNICAL DATA

Version without base height adjustment	29.1-0-00	29.2-0-00	29.3-0-00
Version with base height adjustment	29.1-B-00	29.2-B-00	29.3-B-00
Filling modes	Below-surface	Above-surface	Below-bunghole
Air consumption [NI/cycle]	40	2	30

ELEMENTRA[®] 29

Drum filling equipment

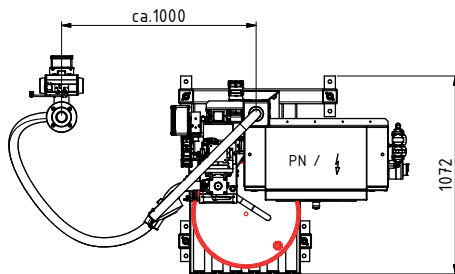
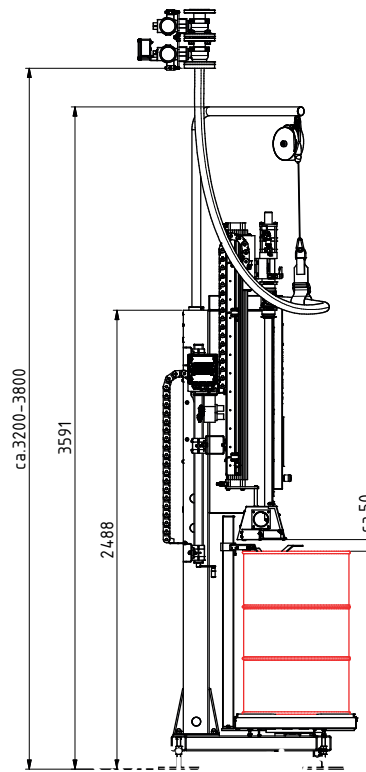
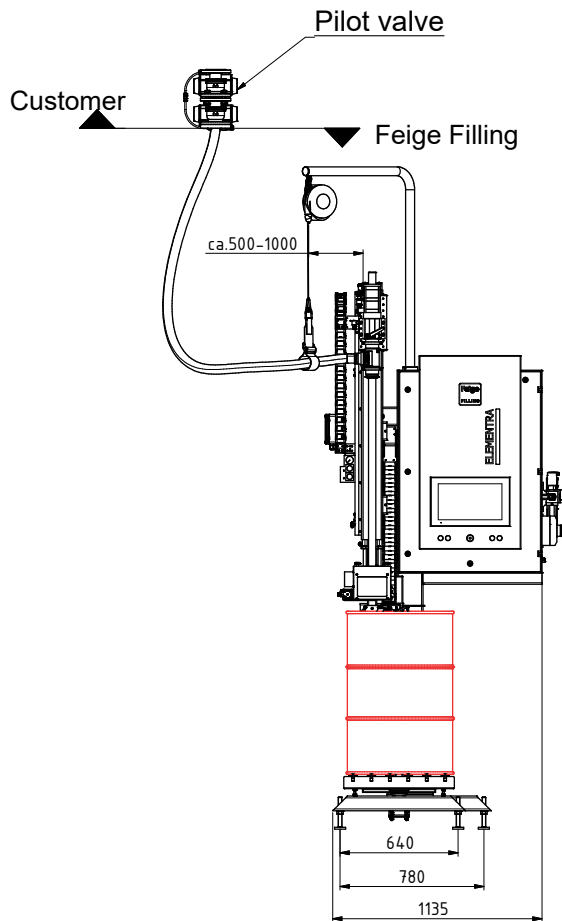

TECHNICAL DATA

ATEX design	Ⓔ II 2G Ex h IIB T3 Gb
Electrical design	3x400V or 230V/N/PE, 50-60Hz, 0.5kVA
Weighing range	10 kg to 300 kg, increment 0.1 kg or 10 kg to 300 kg, increment 0.1 kg, to 400 kg, increment 0.2 kg or 10 kg to 150 kg, increment 0.05 kg, to 300 kg, increment 0.1 kg
External control	2 x dry contacts or 4-20 mA signal for controlling an on-site pump or a pilot valve for coarse/fine fill
Base height range of adjustment	500 mm continuously adjustable via crank handle
Required air pressure	5 bars dynamic
Product connection	Feige square flange
Weight	approx. 300-400 kg, depending on the design
Ambient temperature	5-35°C
Product temperature	0-130°C
Nominal output	50-60 drums/h