

INTEGRA[®] 84

Automatic drum filler

Reliable and well tested. The automatic drum filler INTEGRA[®] 84 is working with 4 stations, thus increasing the efficiency even more. The work processes are continuously monitored. For example, nominal torques for containers and closures are automatically checked. Also possible errors such as missing bunghole seals or wedged plugs are detected by the automatic drum filler.

BENEFITS

- Automatic and monitored opening, closing and sealing, even with leakage test and over-pressure bunging
- Torque evaluation during bunging
- Touch panel
- Components in stainless steel and acid protection design available
- Protective cabin with lock gates available
- Filling of 50 l to 230 l ISO drums with optional accessories
- Variety of essential accessories



TECHNICAL DATA

Below-surface	84.1-0-P0	84.1-0-A0	84.1-0-AZ	84.1-0-AC
Below-bunghole	84.3-0-P0	84.3-0-A0	84.3-0-AZ	84.3-0-AC
Working cycle	positioning/ filling	de-bunging/ filling	de-bunging/ filling bunging	de-bunging / filling bunging/ sealing
Air consumption [NI/cycle]	280	340	390	400

INTEGRA[®] 84

Automatic drum filler

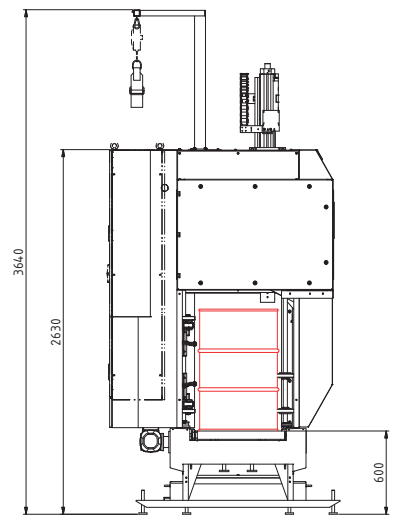
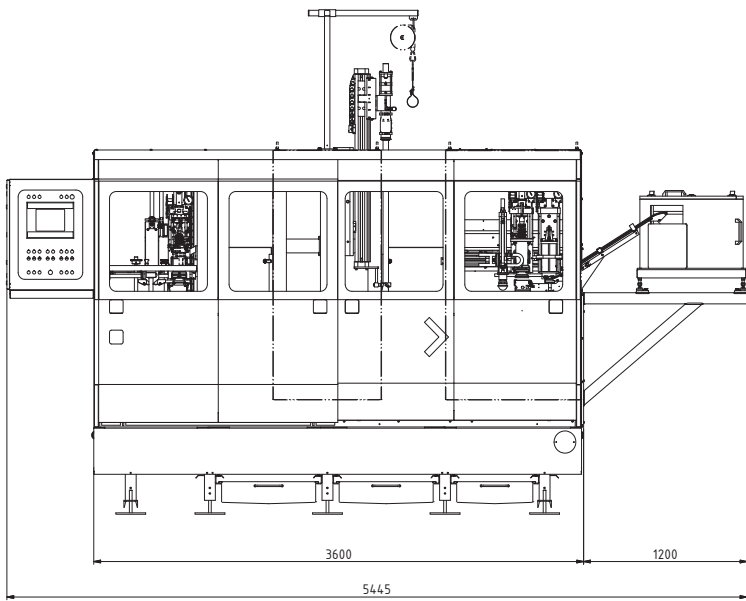

Configuration example

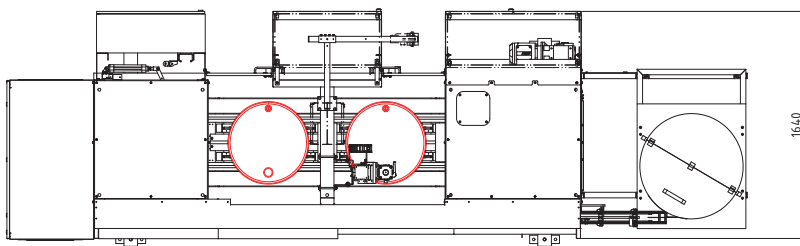

TECHNICAL DATA

ATEX design	Ex II 2G Ex h IIB T3 Gb
Electrical design	3x400V/N/PE, 50Hz, 5kVA
Weighing range	10 kg to 300 kg, increment 0.1 kg or 10 kg to 300 kg, increment 0.1 kg, to 400 kg, increment 0.2 kg or 10 kg to 150 kg, increment 0.05 kg, to 300 kg, increment 0.1 kg
External control	2x dry contacts or 4-20 mA signal for controlling an on-site pump or a pilot valve for coarse/fine fill
Base height range of adjustment	540-970 mm, continuously adjustable with automatic height adjustment
Required air pressure	5 bars dynamic
Weight	approx. 2.600 kg, without accessories
Ambient temperature	5-35°C
Product temperature	0-130°C
Nominal output	up to 110 drums/h for 7l/s in coarse fill