

## ELEMENTRA® 25

Canister filling equipment

Manifold possibilities. The semi-automatic canister filling equipment ELEMENTRA® 25 supports the entire filling process. The equipment can be extended and connected to control systems. Extensive accessories and modular system extensions leave nothing to be desired referring to individual adaptations.

### BENEFITS

- Very flexible filling equipment
- Simple operation
- High variation of different container size
- Control of a complete line
- Huge variety of accessories
- Easy maintenance
- Components in stainless steel and acid protection design available



### TECHNICAL DATA

Version without base height adjustment	25.1-0-00			25.3-0-00
Version with base height adjustment	25.1-B-00			25.3-B-00
Filling modes	Below-surface			Above-surface
Air consumption [NI/cycle]	30			20

# ELEMENTRA<sup>®</sup> 25

Canister filling equipment

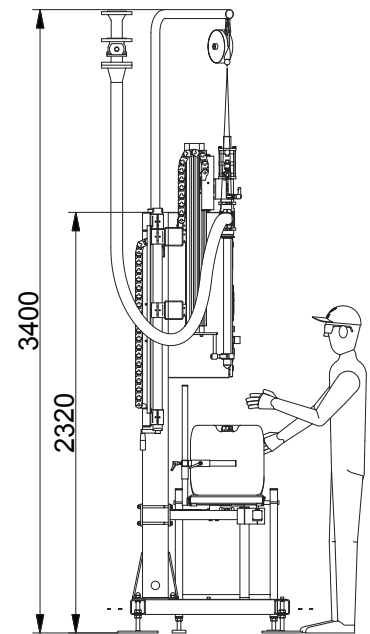
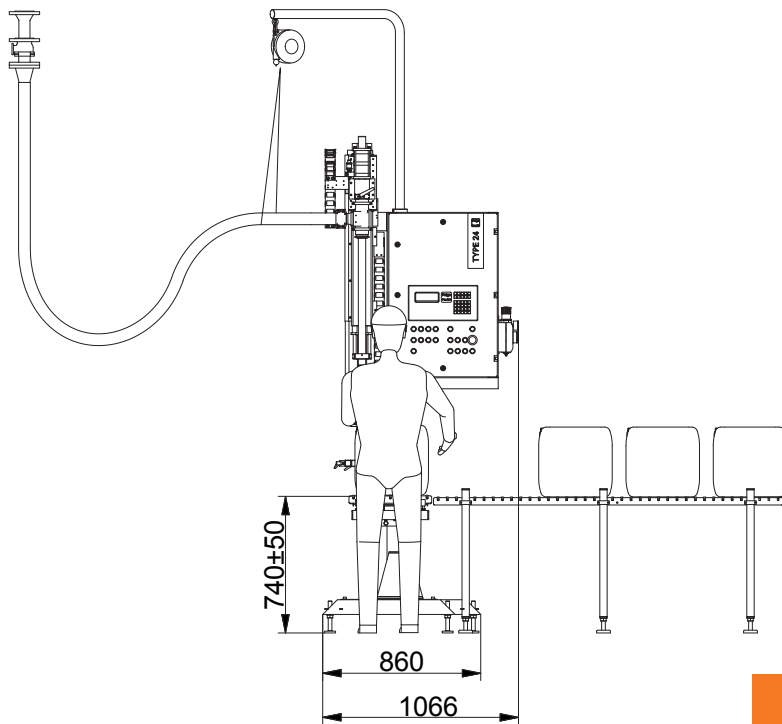

Configuration example

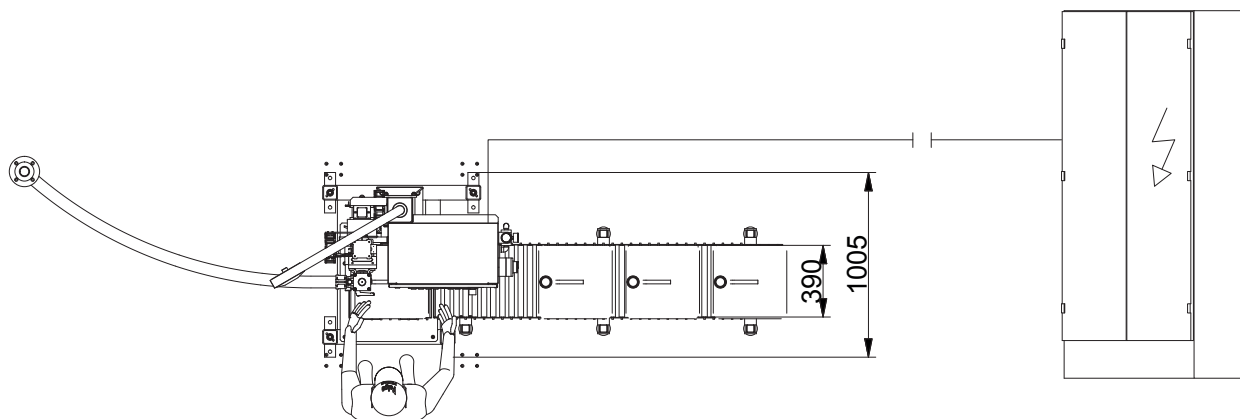

## TECHNICAL DATA

ATEX design	Ex II 2G Ex h IIB T3 Gb
Electrical design	230 V/N/PE, 50-60Hz, 0.5kVA, 3x400 V/N/PE, 50Hz, 2kVA
Weighing range	0.5 kg to 15 kg, increment 0.005 kg, 15 to 30 kg, incr. 0.01 kg or 1.0 to 30 kg, increment 0.01 kg, 30 to 60 kg, incr. 0.02 kg or 0.5 kg to 15 kg, increment 0.005 kg, 15 to 30 kg, incr. 0.01 kg, 30 to 60 kg, incr. 0.02 kg
External control	2 dry contacts or 4-20 mA signal for controlling an on-site pump or a pilot valve for coarse/fine fill
Base height range of adjustment	500 mm continuously adjustable via crank handle (check container according to customer specifications!)
Required air pressure	5 bars dynamic
Product connection	Feige square flange (according to customer specifications)
Weight	approx. 300 kg
Ambient temperature	5-35°C
Product temperature	0-130°C
Nominal output	120-180 canisters/h