

OUR PASSION: OPTIMUM BAG FILLING

A lot of food, animal feed and pet food producers prefer the valve bag. It represents easy handling, high outputs, good weighing accuracies and compact bag shapes with high advertising impact.

Optimum filling results are achieved with the selection of the correct filling system according to the characteristics of your product and your bags.

We can supply:

- Pneumatic packers
- Impeller packers
- Auger packers
- Gravity packers

Our focus: Food, animal feed and pet food

It does not matter whether you fill powders or granules. We have the solution: Packing designs that consider your individual requirements and modern production standards such as GMP or HACCP – as well as the experience our experts have gained in their daily business and trends in the packaging market.

The packing machine is a main part of your value added chain. Being supplied specifically for your product and your conditions, it provides considerable and lasting advantages:

- Maximisation of profit through weight-accurate product processing
- Maximisation of benefit through improved product protection and protection against humidity
- Reduced cost from a clean packing environment and reduced cleaning
- High advertising impact through optimally filled bags that can be efficiently processed by your customers

The linchpin: Your product – Our solution: The right filling technology

The exact analysis of the product and its characteristics as well as the used materials is one of the basic pre-conditions for all processes in the bulk goods handling industry. Our practice-orientated tests lead to economic packaging solutions and facilitate the collection of process-relevant product data.

The target is to get the perfect interplay of product, packing material and machine – and thus optimum filling results.



We analyse your product:
Bulk density, free-flowing properties, humidity, tamped volume, angle of repose

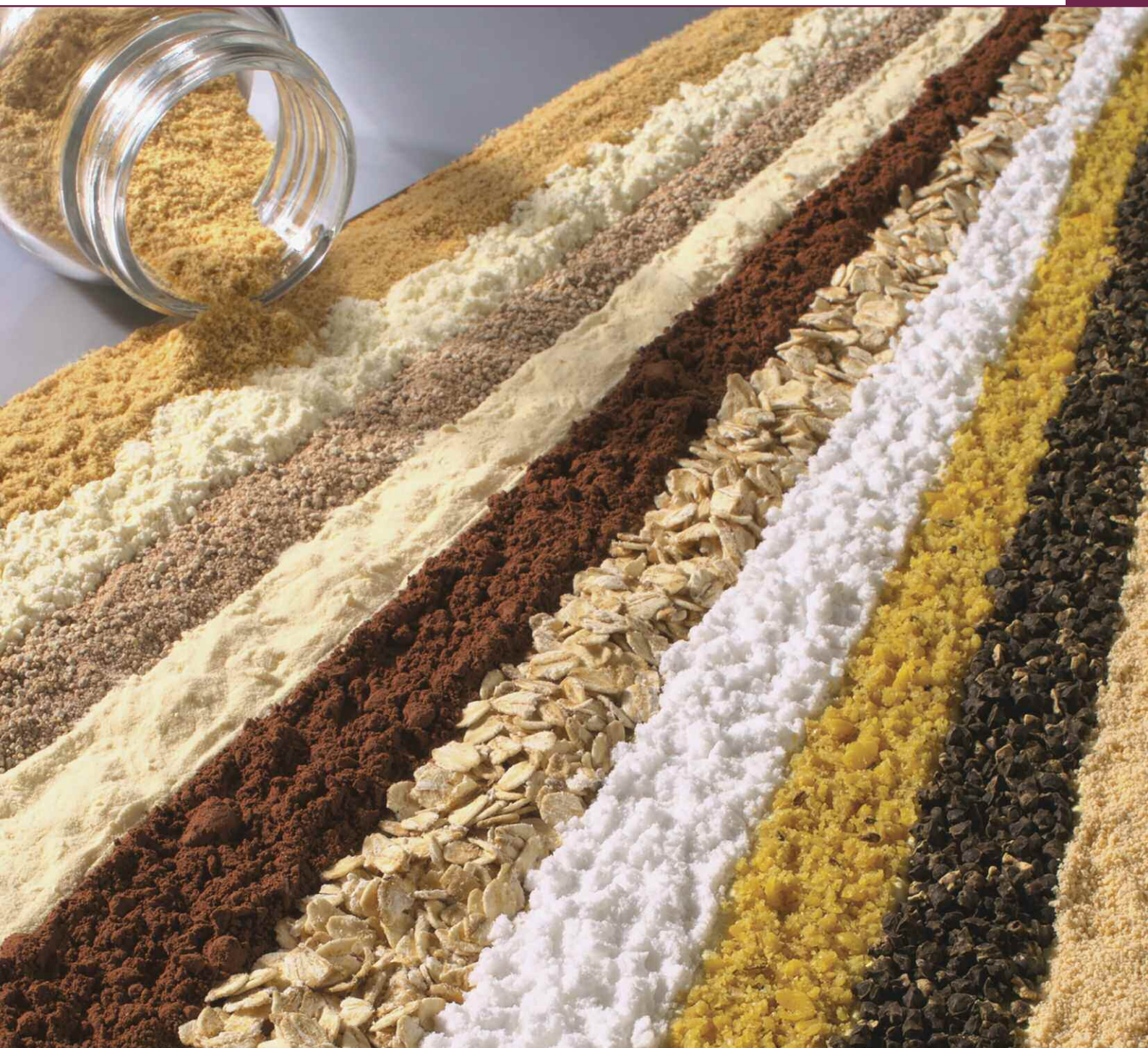

Product	Filling system	Machine output <small>(depending on the product characteristics and the bag size)</small>
Powders, flours & semolina (e.g. starch, sugar, baking mixes, feed additives)	Pneumatic packer as an all-rounder Impeller packer for fine, air-containing products Auger packer for special powders	up to 250 bags/h up to 300 bags/h up to 120 bags/h
Granules & grains (e.g. rice, cereals, seed)	Gross gravity packer Net gravity packer combined with our net weigher	up to 160 bags/h up to 600 bags/h

POWDERS, FLOURS & SEMOLINA: THE PNEUMATIC PACKER

The BEHN + BATES pneumatic packer using the air filling principle is especially suitable for:

- Potato starch and fibres
- Crystal sugar
- Dextrose and maltodextrin
- Flours, baking ingredients and bruised grains
- Soypowder
- Proteins
- Etc.

The continuous product flow from the filling chamber is ensured by the fluidization air quantities being adjustable to your product. During filling the special BEHN + BATES filling and de-aeration nozzle removes the air from the bag.

Machine output:

Up to 250 bags per hour per spout
with filled weights of 10 to 50 kg

Your advantages:

- Cost reduction from weight-accurate product dosing and product-specific control of the material feed by filling level sensors
- High filling outputs with low inner bag pressure and minimized dust occurrence from the special BEHN + BATES de-aeration nozzle with product recycling into the pre-storage silo
- Product-optimized filling process through the fully aerated filling chamber for difficult-to-fluidize products
- Reduced cleaning through minimum residual product quantities
- Reduced energy consumption through product-specific adjustable minimum fluidizing air quantities and thus reduced residual air removal

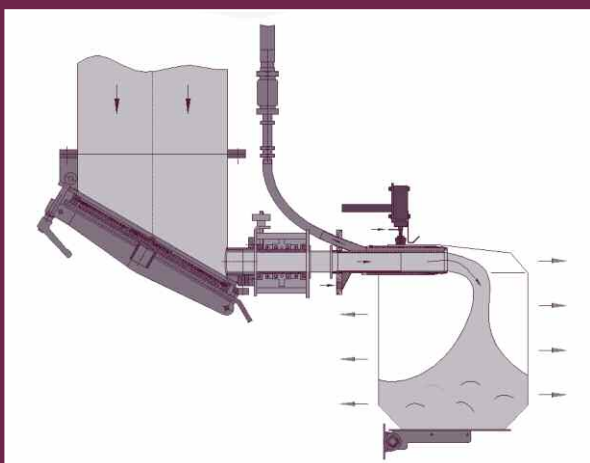

Smooth product filling due to the technical finesse of the pneumatic packer:

- Filling spout with inflatable sleeve for efficient bag seal
- Product-adjusted coarse and fine flow dosing
- Product-specific fluidizing air quantities that can be adjusted separately from each other
- Fast replacement of the aeration plate
- Integrated product spillage tray for easy cleaning

AS AN ALL-ROUNDER



Filling chamber in electro-polished stainless steel design



Chamber bottom: Closed and opened, with product spillage tray for easy and fast cleaning



FINE AND LIGHT POWDERS: THE IMPELLER PACKER

The BEHN + BATES impeller packer achieving best filling results due to low-air filling and high filling pressure is especially suitable for:

- Cocoa powder
- Wheat flour
- Maize starch
- Etc.

The bulk density and the flowability of your product are paramount for the selection of the correct impeller filling system:

- Vertical impeller for fine powders
- Horizontal impeller for heavily flowing and light products, large product infeed section, diameter: 290/400 mm

The diameter of the impeller wheel is selected according to the specific product properties. The high filling pressure ensures compact product filling.

Machine output:

Up to 300 bags per hour per spout
with filled weights of 10 to 50 kg

Your advantages:

- Optimum pallet shape through the especially compact, low-air bag filling
- Improved product shelf life through the reliable filling of tight bags
- No product loss due to the weight-accurate filling by the product-selected filling impeller
- High packing outputs through bag filling without over-pressure and minimum de-aeration times

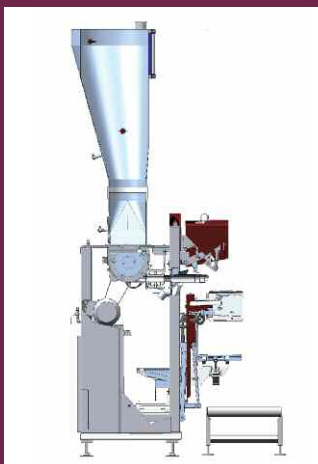

Compact bag filling due to the sophisticated features of the impeller packer design:

- Product-selected design of the filling impeller
- BEHN + BATES filling spout with inflatable sleeve sealing the bag during the filling process resulting in clean and low-dust product processing
- Product-specific adjustable coarse and fine flow dosing
- Low-maintenance drive concept



Optimum product protection

Checking the product for contamination by metal particles is part of the standards in modern food, animal feed and pet food installations. We can offer you various solutions for the integration of a metal detector and testing devices to support you in your quality control and the observation of food regulations.

Sensitivity depending on the product:

1.2 mm for iron particles

1.5 mm for stainless steel particles



SPECIAL POWDERS: THE AUGER PACKER

The BEHN + BATES auger packer is used for the compact filling of badly flowing products:

- Spices
- Fruit powder
- Food additives
- Etc.

The constant product flow into the auger housing is achieved by the continuously operating agitator positioned above the dosing auger. The rotation speed of the dosing auger is adjusted to your product and your requirements for weight-accurate coarse and fine flow product dosing.

Machine output:

Up to 120 bags per hour per filling spout with filled weights of 10 to 50 kg

Your advantages:

- Space savings from the low machine height of only 1,560 mm
- Material savings through the compact filling of very fluidized products
- Improved product storage from the filling of tight bags

The BEHN + BATES gravity packer is the all-round solution for grainy, granular and lumpy products:

- Pellets
- Frozen foods
- Cocoa cake
- Cereals
- Etc.

The product is filled according to the gravity principle – without additional conveying air or mechanical assistance. For optimum product densification the packer can be extended to incorporate a vibrating compactor.

Machine output:

Up to 160 bags per hour with gross weighing

Up to 600 bags per hour with net weighing

Each per filling spout with filled weights of 10 to 50 kg

Your advantages:

- Cost efficiency through the compact, low-maintenance machine design
- Ease of operation through the clear machine design
- Flexibility in combination with a mobile frame enabling positioning of the machine under different silos

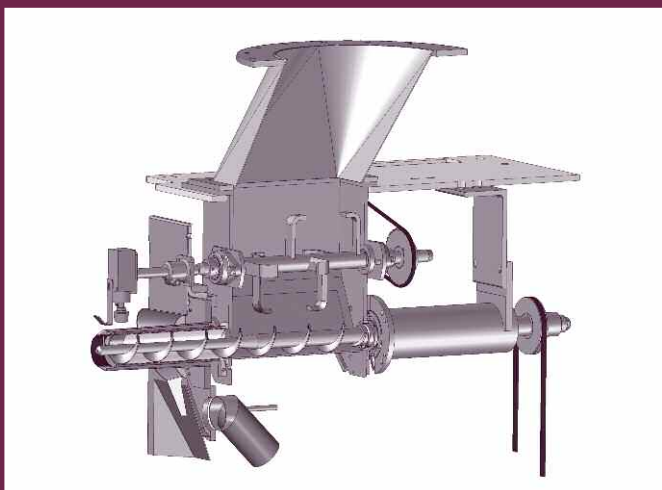

Comfortable filling of special powders with the auger packer:

- Dosing auger with split shaft for easy cleaning
- Special BEHN + BATES de-aeration system for the compact filling of very fluidized products
- Optionally integrated bag vibrator for a better product densification



Cost and space saving filling of granules with the gravity packer:

- Project-specific gravity tube design
 - Curved gravity tube
 - Straight gravity tube for bridging products, for use in conjunction with automatic bag applicators or for higher outputs
- Different dosing systems for different product grain sizes



CUSTOMISED: ACCESSORIES AND CONTROL

You have special demands on your filling machine.
Our flexible modular machine design provides you with the right solution.

- Motor-driven bag length adjustment
- Metal detectors – integrated or external
- Bag vibrator for additional product densification
- Automatic vertical bag discharge
- Printer and labeler for bag marking
- Check weigher for checking the weights and communicating them to the central control system
- Sampling device
- Mobile version enabling positioning of the filling machine under different silos
- Design for wet cleaning (CIP)
- Complete stainless steel design

Your advantage:

Packaging solutions tailor-made to your needs

In addition to ease of operation, weighing and control systems used in packing companies must in particular guarantee the weight accuracy of the filled bags for each product, for each bag type and for both low and high output operations.

All our filling machines are equipped with the MEC® weighing electronics developed within our parent company HAVER & BOECKER specifically for the requirements of the bagging industry.

The functions of the machine are monitored by a large 10.4" infrared touch panel. Operation of our machines is easy and clear thanks to the graphic-supported menu.

All our MEC® and storage programmable controls can be connected through Ethernet or bus systems to the central data processing system.

Your advantage:

Evaluation of your specific filling requirements by the in-house development of the complete weighing and control technologies

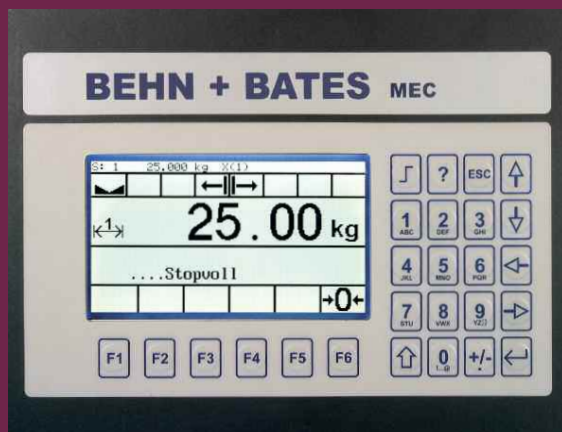

The MEC® weighing electronics

They offer a high operating comfort – especially for your bagging processes:

- Well-structured clear text display of the operational sequences in German, English or your native language
- Easy programming by alpha-numeric keys
- Quick retrieval of your individual filling parameters by the 99-product sort storage in case of product or bag change

More than 18,000 MEC® weighing electronics reliably work around the globe. They comply with international weighing standards as they are OIML approved.



Full bag printing



Belt control weigher

CUSTOMISED: THE AUTOMATIC VALVE BAG FILLING

Minimum product losses and high application rates – the BEHN + BATES FRONTLINE bag applicator applies all common bag types and sizes in a reliable, fast and secure way.

Machine output:

Up to 1,000 bags per hour

Your advantages:

- Cost reduction through the linear bag application and controlled valve opening
- Ideal space use from the possible combination with different bag magazine types and the project-specific positioning of the empty bag magazine
- Reduced maintenance through the free access of the filling machines from the front
- Flexibility from the easy change-over to different bag sizes and types
- Optimum production planning in case of possible future extension of the existing filling machine with minimum interruption of the packing operation

Good product protection and high cleanliness – the BEHN + BATES ultrasound sealing station closes all valves with PE coating in a clean and tight way thus preventing even the smallest product particles escaping from the filled bag.

The valve of the filled bag is sealed by cold welding tools directly at the filling spout.

Machine output:

Depending on the filling machine output

Your advantages:

- Space and cost savings from the integration of the sealing station within the filling machine frame
- Minimum cleaning through clean and fast bag closure directly at the filling spout
- Dust explosion protection with certification according to ATEX for application in the dust-explosion zones 21 or 22



Empty bag magazine carriage



Empty bag feed from the empty bag cassette



Vertical magazine integrated in the machine cabinet for better cleanliness and optimum space use



Valve bag sealing by ultrasound directly at the filling spout



Hermetically closed valve



Your result: Clean and compact pallets with high advertising impact

PLUG 'N PACK: INTEGRA FD

Clean, silent and ready for operation within the shortest possible time – Our “Plug ‘n Pack” design INTEGRA FD sets standards. It integrates the application, filling and sealing stations in a compact dust-tight cabinet that is completely assembled and cabled prior to delivery.

The INTEGRA FD can be supplied with 1 to 4 filling spouts – or alternatively in expandable version for your flexible production planning.

Your product is the decisive factor for the correct selection of the filling principle:

Pneumatic, impeller, auger or gravity packer – everything is possible.

Machine output:

Up to 800 bags per hour
with filled weights of 10 to 50 kg

Your advantages:

- Improved cleanliness from the dust-tight, noise-absorbing cabinet with large-area access doors
- Commissioning costs that are kept to an absolute minimum because the machine is delivered as a completely assembled and tested unit
- Low space requirements from the compact design
- Comfortable operation with the integrated touch panel and the use of polycarbonate windows for the visual control of the packing process
- Flexibility with the possibility of the packer being constructed as a mobile unit



INTEGRA FD 3 for the filling of starch



Inside view of the INTEGRA FD 3



The details make the difference: Label printer for labeling the empty bags

The traceability of products plays an important role in the food, animal feed and pet food industries. Carefully marked bags include information on all important production data.

We offer solutions for the printing of full bags – as well as for the labeling of empty bags providing you with the very special advantage of having the labels reliably applied and always in the same position on the clean bottom of the empty bags. In order to avoid the dust deposit areas, the label printer can, for example, be installed in such a way as to be flush with the cabinet of the INTEGRA FD.



VALVE BAG FILLING TO PERFECTION:

High packing outputs in smallest spaces: We deliver our ROTO-Packer and our ROTOSEAL systems for high-end applications.

In comparison to conventional inline packers the filling spouts of the ROTO-Packer are mounted on a rotating machine frame. Therefore less space is required to reach higher packing outputs with more filling spouts.

Besides the standard ROTO-Packer for self-closing valves we can supply our ROTOSEAL system to hermetically seal the filled valve bags directly at the filling spout with the help of ultrasound energy.

Your product is the task – we have the solution:

The ROTO-Packer and the ROTOSEAL are equipped according to your requirements with either the air or the impeller filling system.

Machine output:

From 600 up to 2,000 bags per hour with filled weights of 10 to 50 kg

Your advantages:

- Optimised cost and space requirements from one central product feed and one central filled bag transport system
- Higher outputs in reduced spaces through the more compact installation of the filling spouts
- Clean product handling from the project-specific selected filling system and bag sealing by ultrasound directly at the filling spout
- Minimum maintenance through continuous bag discharge and the gentle operation of all following plant components
- Simple automation through the possible installation of the automatic valve bag applicator, type RADIMAT

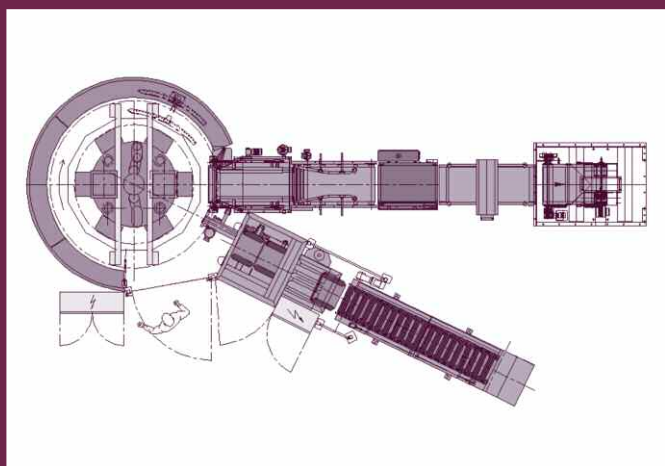

The classic ROTO-Packer or ROTOSEAL installation:

- Empty bag magazine with a length that is variable depending on your required storage capacity
- Automatic valve bag applicator RADIMAT (alternatively: manual operation)
- ROTO-Packer or ROTOSEAL
- Steady full bag discharge and transport to the palletizing

ROTO-PACKER AND ROTOSEAL



Gradual increase in production

If you need to respond flexibly to the demand for your product, we can help you with the implementation. We can deliver our ROTO-Packer and our ROTOSEAL in expandable version:

- 3/4 spouts to 6 spouts
- 4/6 spouts to 8 spouts
- 5 to 10 spouts

You profit from an optimised production planning. The spouts can be retrofitted individually. The packing output can be increased by 100 % within a short time – without any changes to the prior or subsequent plant components.

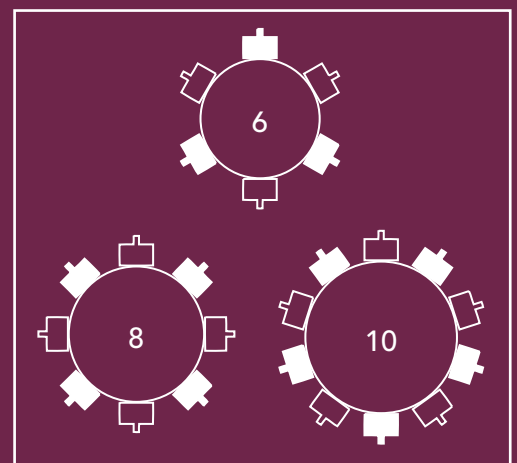

ALL FROM THE ONE SOURCE:

Your convincing and attractively packaged bags are the result of a detailed planning, a carefully selected filling technology and an overall concept incorporating the prior and subsequent plant components.

We plan, project and deliver the single filling machine as well as complete packing lines with palletizing and transport packaging. Depending on your requirements, we can offer robotic palletizing or a conventional high-level palletizer in conjunction with stretch wrapping or stretch hooding.

In addition to this, our plant engineering includes the product feed with pre-storage silos, metal detectors or filter plants. We thus are able to develop comprehensive solutions for hygienic, reliable and economic packing processes – all this in close co-operation with you.

Our experience is your profit:

From single filling machines up to complete packing lines – all are planned and realized on a turnkey basis from one source.

Service around your filling plants: It is important to us to commission your packaging plant successfully – and moreover, to keep it running trouble-free over the years.

A team of well-trained service technicians, who have extensive experience in packaging technologies, is at your disposal to quickly install and commission your plant and offer regular maintenance to achieve the highest possible reliability in continuous operation. Should problems still occur, they are solved rapidly. Our large stock enables the quick delivery of spare parts.

On request, we are able to equip your machine for our teleservice. We can then log into the control of your machine for remote diagnosis to best assist you in case of any problems.

BEHN + BATES solutions are perfect solutions – for all food, pet food and animal feed products!

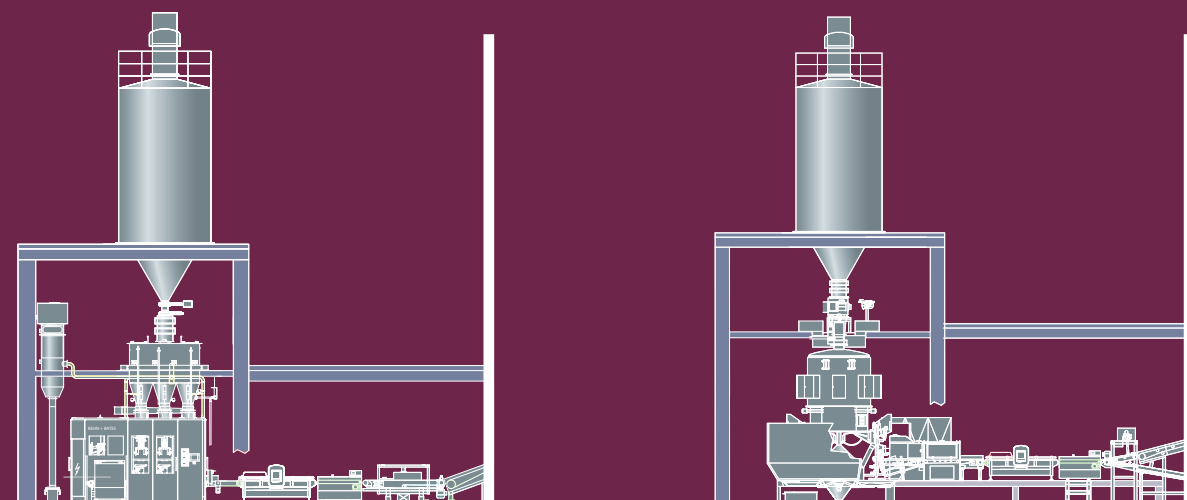

PLANT ENGINEERING AND SERVICE



Integral planning concept

We plan your entire packaging plant – from product storage up to the fully packaged filled bag pallet with transport protection.

LOCAL CONTACTS

BRAZIL

HAYER & BOECKER Latinoamericana

Industria e Comercio de Maquinas Ltda.
Rod. Campinas a Monte Mor km 20
13190 Monte Mor S.P.
Telephone: +55 19 38 79 91 01
Telefax: +55 19 38 79 14 10
haverhbl@haverbrasil.com.br
www.haverbrasil.com.br

CHILE

HAYER & BOECKER Andina

Marchant Pereira 150,
of. 401-402, Providencia
CP 7500523 Santiago
Telephone: +56 2 9527 - 900/901/902
haverandina@haverandina.cl
www.haverandina.cl

CHINA

HAYER TECHNOLOGIES (Tianjin) Ltd.

North Area of Wuqing Development
Zone III, East Quanhua Road,
New Tech Park, Tianjin,
Post Code: 301700
Telephone: +86 22 5898 3800
Telefax: +86 22 5898 3801
htt@havertechnologies.com
www.havertechnologies.com

BEHN + BATES Maschinenfabrik GmbH & Co. KG

Robert-Bosch-Straße 6 · 48153 MÜNSTER · GERMANY
Telephone: +49 251 9796-0 · Telefax: +49 251 9796-260
E-mail: sales@behn-bates.com
Internet: www.behn-bates.com

FRANCE

HAYER FRANCE S.A.R.L.

ZA 7, rue des Bauches
78260 Achères
Telephone: +33 1 39118080
Telefax: +33 1 39118089
contact@haverfrance.fr
www.haverfrance.fr

GREAT BRITAIN

HAYER CONTINENTAL LIMITED

24B Invincible Road,
Farnborough GU14 7QU,
Hampshire, England
Telephone: +44 1252 512 122
Telefax: +44 1252 549 291
info@havercontinental.com
www.havercontinental.com

MALAYSIA

Regional BEHN + BATES

Sales Office SEA

Kong Chee Wai, Unit B-12-02, PV 13
Platinum Lake Condo, No. 9,
Jalan Danau Saujana 1, Danau Kota
53300 Kuala Lumpur
Telephone: +60 367325711
+60 123083834
c.kong@behn-bates.com

POLAND

HAYER TRADING SP. Z.O.O.

ul. Kolejowa 3
Bielany Wroclawskie
55-040 Kobierzyce
Telephone: +48 717960204
Telefax: +48 717960205
htr@haverboecker.com
www.havertrading.pl

RUSSIA

HAYER Russia

Gostinichny proezd, 8/1, Office 51
127106 Moscow
Telephone: +7 49 57 83 34 48
Telefax: +7 49 57 83 34 48
haverboecker@haverrussia.ru
Internet: www.haverrussia.ru

SPAIN

HAYER & BOECKER IBERICA

Plaza Tetuan 40 2ª Planta, oficina 37
08010 Barcelona
Telephone: +34 932476190
Telefax: +34 932476191
hbi@haverboecker.com
www.haver.es

UNITED ARAB EMIRATES

HAYER MIDDLE EAST FZE

Amenity Tower 2 - Office 8F-03
Al Jazeera Al Hamra, Ras Al Khaimah
Telephone: +971 72434711
Telefax: +971 72434712
office@havermiddleeast.com
www.havermiddleeast.com

USA AND CENTRAL AMERICA

BEHN + BATES AMERICA

A Division of
HAYER FILLING SYSTEMS, INC.
460 Gees Mill Business Court
Conyers, GA 30013
Telephone: +1 7703887886
Telefax: +1 7707601181
foodpackaging@behn-bates-usa.com
www.behn-bates-usa.com

... AND REPRESENTATIVES WORLD-WIDE

