



SERIES 10

AUGER HEAD FOR VFFS MACHINES



The AFI Series 10 VFFS filling head provides the perfect configuration when integrated with a vertical-form-fill-seal bagging system.

The sleeved mount permits rotation of the head for ease of tooling/hopper removal, with the choice of servo motor, flux vector and clutch brake drive to suit the application.

FEATURES

- OEM swivel mount
- All stainless steel contact parts
- No-tools removable change parts
- Precision augers machined from solid
- Independent agitation drive
- Large capacity seamless hopper
- Plc control via touch-screen HMI
- Interlocked hopper inspection cover
- Integrated control cabinet to match vffs machine



OPTIONS

- Product recipe memory
- Horizontal auger and other bulk feed accessories
- Checkweigher feedback
- Level probe
- Single and twin acting flaps



ALL-FILL INTERNATIONAL LIMITED
REGISTERED TO ISO 9001
CERTIFICATE NO. A6246



ALL-FILL INTERNATIONAL LIMITED
Unit 5 Gateshead Close • Sunderland Road
Sandy • Bedfordshire • SG19 1RS • UK

tel: +44 (0) 1767 691100
fax: +44 (0) 1767 681406
email: info@allfill.co.uk
website: www.allfill.co.uk

TYPICAL BULK FEED OPTIONS

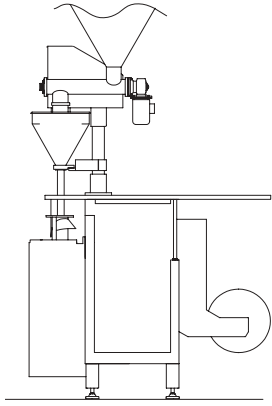

From overhead IBC/bulk bin via horizontal auger.

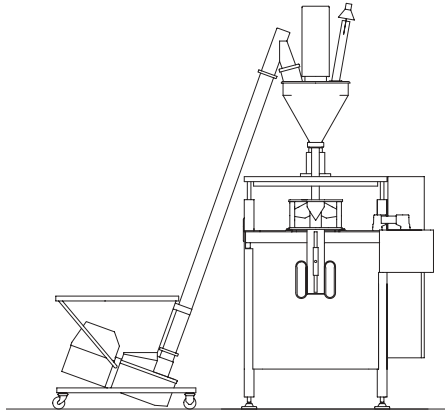

From sacks or drums at ground level via inclined auger screw

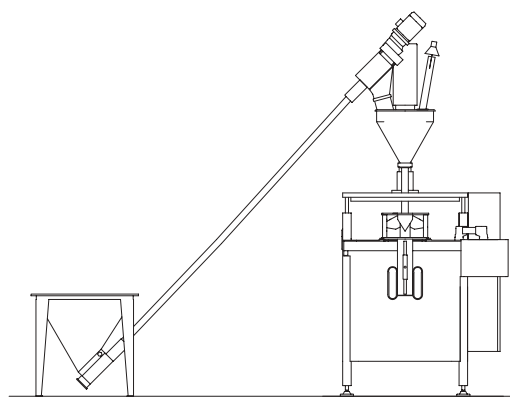

From sacks or drums at ground level via inclined flexible spiral

STANDARD SPECIFICATION

Controller type:	Siemens touch-screen HMI
Hopper capacity:	38 litres
Agitation drive:	0.37 kw, 28 rpm
Agitation options:	Continuous With fill only With fill and variable time delay No agitation
Fill method	
Auger revs:	0.005 rev incremental adjustment (flex vector) 0.0003 rev incremental adjustment (servo)
Time:	0.001 sec incremental adjustment
Auger tooling:	Manufactured from solid stainless steel
Contact parts:	304 grade stainless steel
Fill weight range:	20mg to 50kg
Power:	2.2 kva
Weight:	175kg

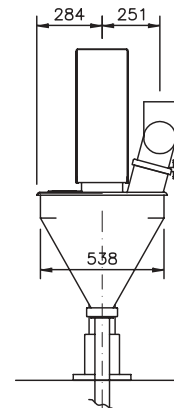
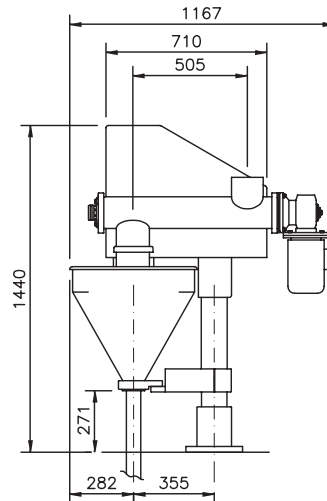

DRIVE SYSTEM OPTIONS

- Flux Vector Inverter direct drive system
- Servo direct drive system
- Self-adjusting 170mm diameter heavy duty clutch brake

OTHER OPTIONS

- Full stainless steel specification
- 316L contact parts for pharmaceutical applications
- 56 litre capacity hopper
- Easi-view hopper
- Jacking system
- Gassing system for sensitive powders
- Full colour touch-screen HMI panel
- Checkweigher feedback



ALL-FILL INTERNATIONAL LIMITED
Unit 5 Gateshead Close • Sunderland Road
Sandy • Bedfordshire • SG19 1RS • UK

tel: +44 (0) 1767 691100
fax: +44 (0) 1767 681406
email: info@allfill.co.uk
website: www.allfill.co.uk