

Roller Compactors **PP500**

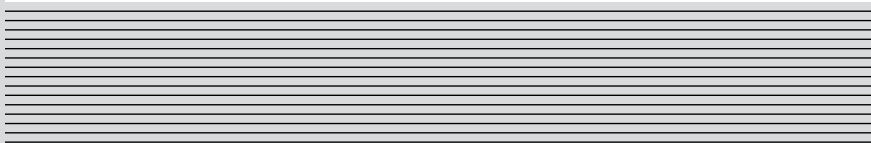
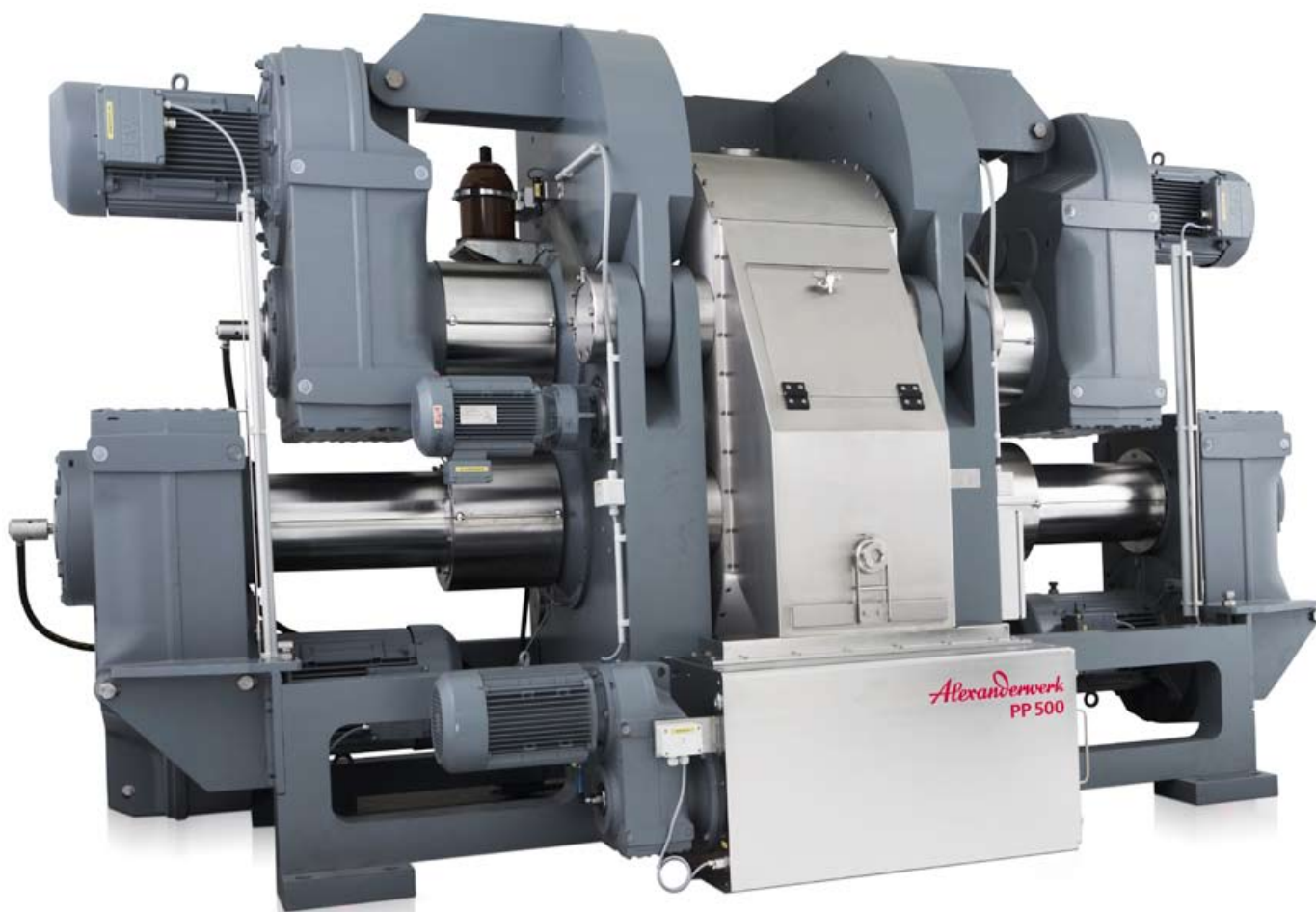

The King of Roller Compactors

PP 500

With the PP 500, Alexanderwerk offers a compactor and granulator specifically designed for use in the chemical industry. The PP 500 stands for the economic compaction of raw materials, with a throughput of up to 50,000 kg/hr and more.

- Extensive use of standard components for high machine availability
- Compact design
- Patented Combi-Vent-Feeder® System as standard
- Feed unit in vacuum design as standard
- Each roller is driven by two gear motors
- Various roller widths with adjusted number of screws (1 to 4 screws available)
- optional: Wash in Place (WIP)
- optional: explosion-proof acc. to ATEX

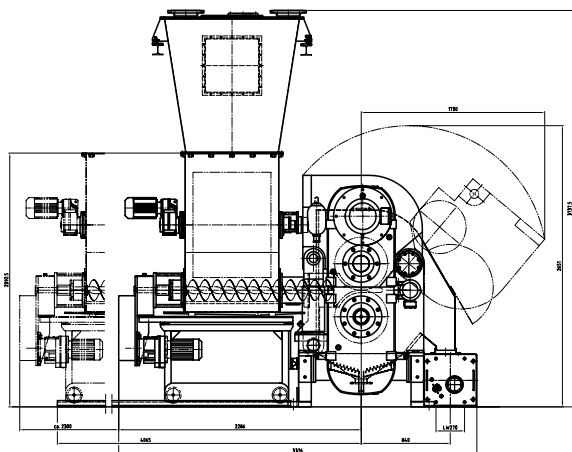

CAD data show the PP 500

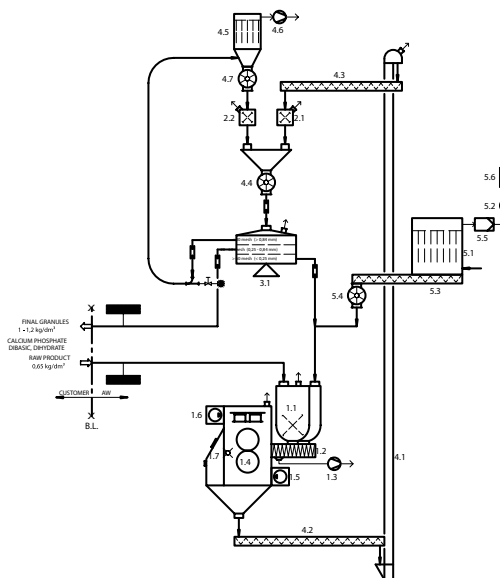

Example of integration of the PP 500 into the complete system

Technical Data

Throughput, continuous operation	to 50,000 kg/hr
Granule size	variable
Maximum compacting pressure	2,400 kN
Installed power	approx. 256 kW
Weight	approx. 25 t (complete, without control)
Product contact material	1.4571
Compacting rollers	1.4122